



ACE INSTRUMENTATION



Fuel Consumption Measurement



50 Kallang Pudding Road, #05-05, Golden Wheel Industrial Building, Singapore 349326
Tel : +65 6744 0564 Fax : +65 6744 0546 24-Hrs Co. Mobile : +65 9452 3712
Email : info@aceinstrumentation.com Website : www.aceinstrumentation.com





ACE INSTRUMENTATION

Introduction

Due to the increasing awareness of the impact of exhaust emissions on the environment, combined with the continued increases in fuel costs, there is great need for reduction in fuel consumption. This has led to a high demand for accurate measurement systems to monitor the fuel consumption per engine. For the large variety in fuel systems, VAF Instruments offers a modular fuel consumption measurement system.

Where can fuel consumption be measured ?

Fuel consumption measurement can be performed in engine-driven installations in all kinds of power and propulsion plants. Various types of fuel can be measured, such as heavy fuel oil, marine diesel oil or bio-oils. Depending on the design of the fuel system and the preferences of the customer one or multiple flowmeters can be used in combination with temperature compensation to obtain the most accurate measurements.

Your advantage

VAF Instruments has over 75 years experience in the development, production and application of precision measuring instruments for (fuel) flow measurement. The very high accuracy (down to 0.1%) and high repeatability (0.05%) of the flow meters are not affected by pressure, viscosity or temperature of the fuel. In addition the design of the systems is very robust and easy to operate, making them ideal for use in the typical environmental conditions on board ships or power plants. Depending on the specifications and requirements, a large variety of counters, computers and flowmeters with integrated temperature sensors is available.

Quality

VAF Instruments demonstrates its trust in its products by giving a standard two year guarantee. This longest and most comprehensive guarantee in the maritime industry is our commitment to our clients and reflects the constant quality of our products.

Fuel consumption measurement

Most of the operating costs of a ship are fuel related. Therefore it is very important to use fuel in the most efficient way. The real-time measurement of fuel consumption provides helpful information for shipowners, shipmanagers and crew about the influences of their actions on the consumed fuel. VAF Instruments offers various kinds of systems for the most accurate measurement of fuel consumption.

In most fuel systems fuel is circulated over the engine with a flow rate which is 2,5 to 5 times the maximum fuel consumption. When the engine consumes fuel, this is taken out of the circulation circuit. To maintain the fuel flow in the circulation system, new fuel is supplied from the daytank. Directly measuring the fuel flow from daytank to circulation system is therefore the easiest and most accurate solution.

There are fuel systems where these measurements are not possible or give too little information, for example when there is no closed circulation circuit or when there are multiple consumers (unifuel systems).

In that case it is necessary to measure both supply and return flow from an engine and calculate the difference to obtain the fuel consumption. Since there is also a temperature difference between supply and return flow, compensation for temperature is necessary.

Why is temperature compensation needed?

When measuring the fuel consumption over an engine, it is often necessary to install one flowmeter in the fuel supply line towards the engine and one flowmeter in the fuel return line. In such system it is absolutely necessary to have temperature compensation for the calculation of the fuel consumption, because the volume flow is temperature dependent and there will be temperature difference between the fuel in the supply line and the fuel in the return line.

When not compensating for these temperature effects there will be a decreased accuracy in the calculated volume.

This inaccuracy is almost 1% for each 10°C temperature difference when not compensated. Because the circulation flow is in general 2,5 to 5 times the maximum fuel consumption, this means that the error on the calculated fuel consumption will also at least be multiplied by 2,5 to 5.



50 Kallang Pudding Road, #05-05, Golden Wheel Industrial Building, Singapore 349326
Tel : +65 6744 0564 Fax : +65 6744 0546 24-Hrs Co. Mobile : +65 9452 3712
Email : info@aceinstrumentation.com Website : www.aceinstrumentation.com





ACE INSTRUMENTATION

Typical system arrangements

Single flowmeter system

A single flowmeter system provides the most accurate fuel consumption measurement, measuring the fuel flow between daytank and the circulation system. Temperature compensation can be used if the volume at a specified reference temperature (e.g. at 15°C) is required, for example when comparing (sister) vessels or voyages. VAF Instruments offers a wide range of flow computers to meet the demands and requirements for the displayed information and data output.

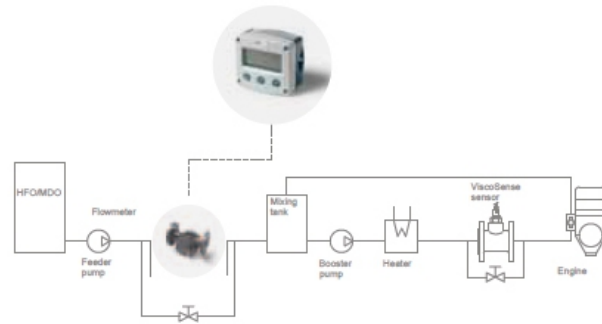

Single flowmeter system

Supply and return flowmeter system

When it is not possible to measure the fuel consumption with a single flowmeter, the consumption can be calculated from the difference between the fuel supply and return flow. For this layout the volume flow and the actual temperature from both supply and return should be measured and the difference calculated real-time.

A typical system consists of flowmeters with integrated PT100, and a flowcomputer displaying information about the supply and return fuel flow, temperatures, the actual- temperature compensated- fuel consumption and totals.

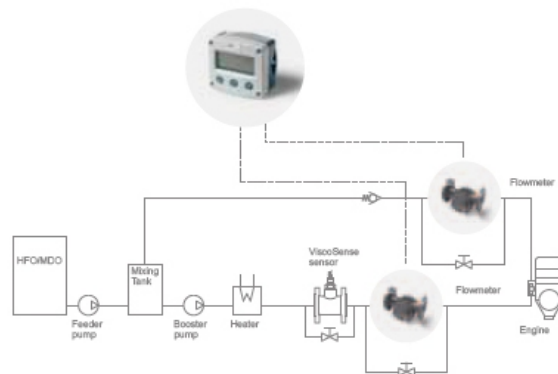

Supply and return flowmeter system

Uni-fuel system

In uni-fuel systems there are multiple engines supplied from the same fuel treatment system, for example both main engine and auxiliary engine(s). If information about fuel consumption for each engine(group) is needed, separate supply and return flowmeter systems should be installed.

Another solution is using a setup consisting of three flowmeters, strategically placed. For this solution a single flowmeter is placed between daytank and the fuel circulation system to measure the total fuel consumption.

Additional flowmeters will be installed in the fuel supply and return lines from the auxiliary engine(s), measuring the consumption of this engine only. By subtraction the consumption data from the other engine is calculated.

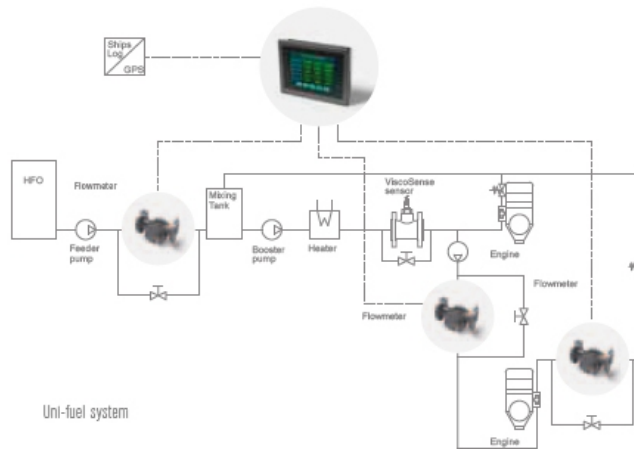

Uni-fuel system

For monitoring of the consumption data VAF Instruments has developed the PEM2 fuel consumption monitor. On its large touch screen display all important information is available at a glance. The intuitive navigation through the different screens offers not only real-time consumption data (compensated for temperature differences), but also other valuable information. For example the average fuel consumption over a customer specified period of time can be given. It is also possible to connect a speed signal (from the ships speed log or GPS) to obtain the specific fuel consumption per nautical mile.

VAF Instruments' Ship Efficiency Solution

To obtain even more insight in the efficiency of the total fuel consumption on ships VAF Instruments can supply, for a large variety in fuel systems, a modular fuel consumption measurement system. The system can be extended to monitor up to 8 flowmeters (4 separate consumers). Depending on the fuel system lay out drawing and your requirements, our engineers are able to configure a tailor made solution.

Further insight in fuel consumption and propulsion efficiency can be reached by combining the fuel flow measurement with shaft power measurement. Please refer to Product Bulletin 660 for more information about fuel consumption measurement in combination with the innovative T-Sense optical torque measuring system.



50 Kallang Pudding Road, #05-05, Golden Wheel Industrial Building, Singapore 349326
Tel : +65 6744 0564 Fax : +65 6744 0546 24-Hrs Co. Mobile : +65 9452 3712
Email : info@aceinstrumentation.com Website : www.aceinstrumentation.com





ACE INSTRUMENTATION

Technical specification

All flowmeters provided by VAF Instruments can be used in the flowcomputer solutions for fuel consumption measurement. However due to the high importance of temperature compensation we strongly advise the flowmeter type Midflow PT with integrated PT100. For more information please refer to Product Bulletin 135.

Single flowmeter system

For display of the measured data in combination with a single flowmeter, VAF Instruments can deliver flowcomputer types F011, F014, F110 and F126. Depending on the version the computer includes temperature compensation. The flowcomputers can be delivered in both panel mount and field mount housing.

Display	Seven 17 mm digits + eleven 8 mm digits
Output (optional)	4-20 mA passive, galvanically isolated / pulse output (scalable)
Ambient temperature	-20°C / 60°C
Power supply	24 VDC (or Lithium battery, F011 and F014 only)
Enclosures	Aluminium field mount IP67 or ABS panel mount IP65
Dimensions	130 x 120 x 75 mm or 130 x 120 x 61 mm
Panel	Cut-out 115 x 98 mm
Input	Pulse from flowmeter PT100 from flowmeter (optional)

Display and output options

	F011	F014	F110	F126
Temperature compensation	No	No	No	Yes
Pulse output (scalable)	No	Yes	Yes	No
Analog output 4-20 mA	No	No	Yes	Yes
Instantaneous flow rate	No	Yes	Yes	Yes
Instantaneous temperature	No	No	No	Yes
Total (accumulated)	Yes	Yes	Yes	Yes



50 Kallang Pudding Road, #05-05, Golden Wheel Industrial Building, Singapore 349326
Tel : +65 6744 0564 Fax : +65 6744 0546 24-Hrs Co. Mobile : +65 9452 3712
Email : info@aceinstrumentation.com Website : www.aceinstrumentation.com





ACE INSTRUMENTATION

Supply and return flowmeter system

For display of the measured data in a supply and return flowmeter system, VAF Instruments can deliver flowcomputer type F127 with standard temperature compensation and analog / relay outputs. The flowcomputer can be delivered in both panel mount and field mount housing.

Display	Seven 17 mm digits + eleven 8 mm digits
Output (optional)	4-20 mA passive, galvanically isolated
Ambient temperature	-20°C / 60°C
Power supply	24 VDC
Enclosures	Aluminium field mount IP67 or ABS panel mount IP65
Dimensions	130 x 120 x 75 mm or 130 x 120 x 61 mm
Panel	Cut-out 115 x 98 mm
Input	2 x pulse from flowmeter 2 x PT100 from flowmeter

Display and output options

	F127
Temperature compensation	Yes
Pulse output (scalable)	Yes
Analog output 4-20 mA	Yes
Instantaneous flow rate	Yes
Instantaneous temperature	Yes
Total (accumulated)	Yes

Uni-Fuel system solution

For the uni-fuel systems and other configurations, VAF Instruments can deliver the PEM2 display unit in combination with a separate signal processing unit. The components are interconnected through RS485 giving great flexibility in installation position.

Power supply	24 VDC
Display touch screen	320 x 240 pixels
Ambient temperature	0°C to 55°C
Dimensions	186 x 145 x 45 mm
Enclosures	panel mount IP65
Input	3 to 8 x pulse from flowmeter 3 to 8 x PT100 from flowmeter Speed log as pulse input or GPS (NMEA) signal



50 Kallang Pudding Road, #05-05, Golden Wheel Industrial Building, Singapore 349326
 Tel : +65 6744 0564 Fax : +65 6744 0546 24-Hrs Co. Mobile : +65 9452 3712
 Email : info@aceinstrumentation.com Website : www.aceinstrumentation.com





ACE INSTRUMENTATION

Dimensions

F011 / F014 / F110 / F126 / F127

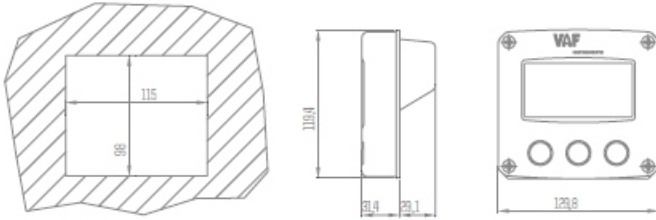

Panel mount

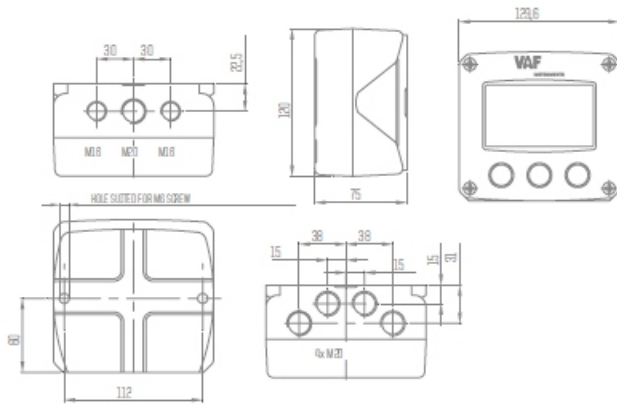

Field mount

PEM2 display unit

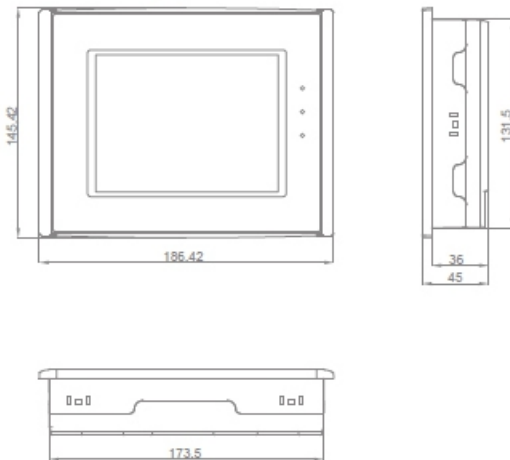

Touch screen

Signal processing unit

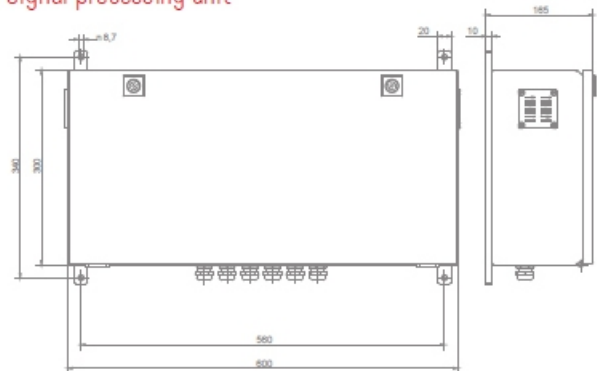

50 Kallang Pudding Road, #05-05, Golden Wheel Industrial Building, Singapore 349326
Tel : +65 6744 0564 Fax : +65 6744 0546 24-Hrs Co. Mobile : +65 9452 3712
Email : info@aceinstrumentation.com Website : www.aceinstrumentation.com

